



NCS-TT106F

FOUNDATION FIELDBUS series  
Intelligent Temperature Transmitter  
**User Manual**

## Warning

1. It is forbidden for users to disassemble the temperature module by themselves.
2. Please check if the supply voltage of temperature transmitter meets the power supply voltage requirements in the manual.

**Version: V1.0**

### Disclaimer

The contents of this manual have been checked to confirm the consistency of the hardware and software described. Since errors cannot be completely ruled out, absolute consistency cannot be guaranteed. However, we will regularly check the data in this manual and make necessary corrections in subsequent versions. Any suggestions for improvement are welcome.

**Microcyber Corporation 2020**

Technical data is subject to change.

## Company Introduction

Microcyber Corporation, established as a high-tech enterprise by the Shenyang Institute of Automation Chinese Academy of Sciences, mainly engages in advanced industrial control systems, equipments, instruments and chips for industrial process automation control solutions in the research, development, production and application. Microcyber undertakes a number of national scientific and technical key task and “863” project, and has Liaoning Province networked control systems engineering research center.

Microcyber successfully developed the FF H1 fieldbus protocol stack which is number one to be approved internationally in China, and the Industrial Ethernet Protocol(HSE) which is number one to be approved in China, and the domestic first fieldbus instrument which has a function of national-level intrinsically safe explosion--proof and safety barrier. Also Microcyber participated in the drafting of the domestic first Ethernet-based industrial automation protocol standards (Ethernet for Plant Automation, EPA). As a result, serial products are composed of configuration, control software, embedded software, control system, instrument chip to the OEM board, and make Microcyber be an industrial automation products provider in full range, and also further Microcyber’s leading position in the field of fieldbus technology.

Microcyber is the member of FieldComm Group(FCG) and Profibus National Organization (PNO) .

Microcyber passes the Authentication of ISO 9001 Quality System, and has an outstanding innovative R&D team, plentiful practical experiences of design of the Automatic engineering, a leading product series, a huge market network, a strict quality management system and an excellent enterprise culture. All these further a solid foundation of entrepreneurship and sustainable development for Microcyber.

Carrying the ideals of employees, creating customer value and promoting enterprise development.

## CATALOGUE

1	OVERVIEW .....	1
2	TEMPERATURE TRANSMITTER INSTALLATION .....	2
2.1	DIMENSIONS .....	2
2.2	INSTALLATION .....	2
2.3	WIRING .....	4
3	FOUNDATION FIELDBUS PROTOCOL TEMPERATURE TRANSMITTER CONFIGURATION .....	5
3.1	TOPOLOGY CONNECTION .....	5
3.2	FUNCTION BLOCK .....	6
3.3	TRANSDUCER BLOCK CONFIGURATION EXAMPLE .....	6
3.3.1	Connecting a resistance sensor .....	6
3.3.2	Connect RTD thermal resistance sensor .....	7
3.3.3	Connect- / + 100mV signal sensor .....	7
3.3.4	Connect TC Thermocouple Sensor .....	7
3.3.5	Custom TC thermocouple sensor .....	7
3.3.6	Custom RTD thermal resistance sensor .....	8
3.4	FUNCTION CONFIGURATION .....	8
3.4.1	Setting up the configuration environment .....	9
3.4.2	Import DD file .....	9
3.4.3	Device online detection .....	10
3.4.4	Sensor configuration .....	10
3.4.5	Two-wire zero calibration configuration .....	11
3.4.6	Two-point linearization calibration .....	12
3.4.7	Multipoint linearization calibration .....	13
3.4.8	Enabling cold junction temperature compensation .....	14
3.5	FUNCTION BLOCK CONFIGURATION .....	15
4	MAINTENANCE .....	20
5	TECHNICAL SPECIFICATIONS .....	21
5.1	BASIC PARAMETERS .....	21
5.2	THERMAL RESISTANCE TECHNICAL INDEX .....	21
5.3	THERMOCOUPLE TECHNICAL INDICATORS .....	22
5.4	PHYSICAL CHARACTERISTICS .....	22

## 1 Overview

NCS-TT106F intelligent temperature transmitter adopts field bus technology, is a new generation of intelligent temperature transmitter, is an indispensable field device in process control. The device integrates a wealth of functional modules, which can achieve both general detection functions and complex control strategies.

NCS-TT106F adopts digital technology and can be applied to a variety of thermal resistance and thermocouple sensors. It has a wide measuring range and a simple interface between the field and the control room.

NCS-TT106F series intelligent temperature transmitter supports Foundation Fieldbus protocol, which can be widely used in petroleum, chemical, electric power, metallurgy and other industries.

## 2 Temperature transmitter installation

### 2.1 Dimensions

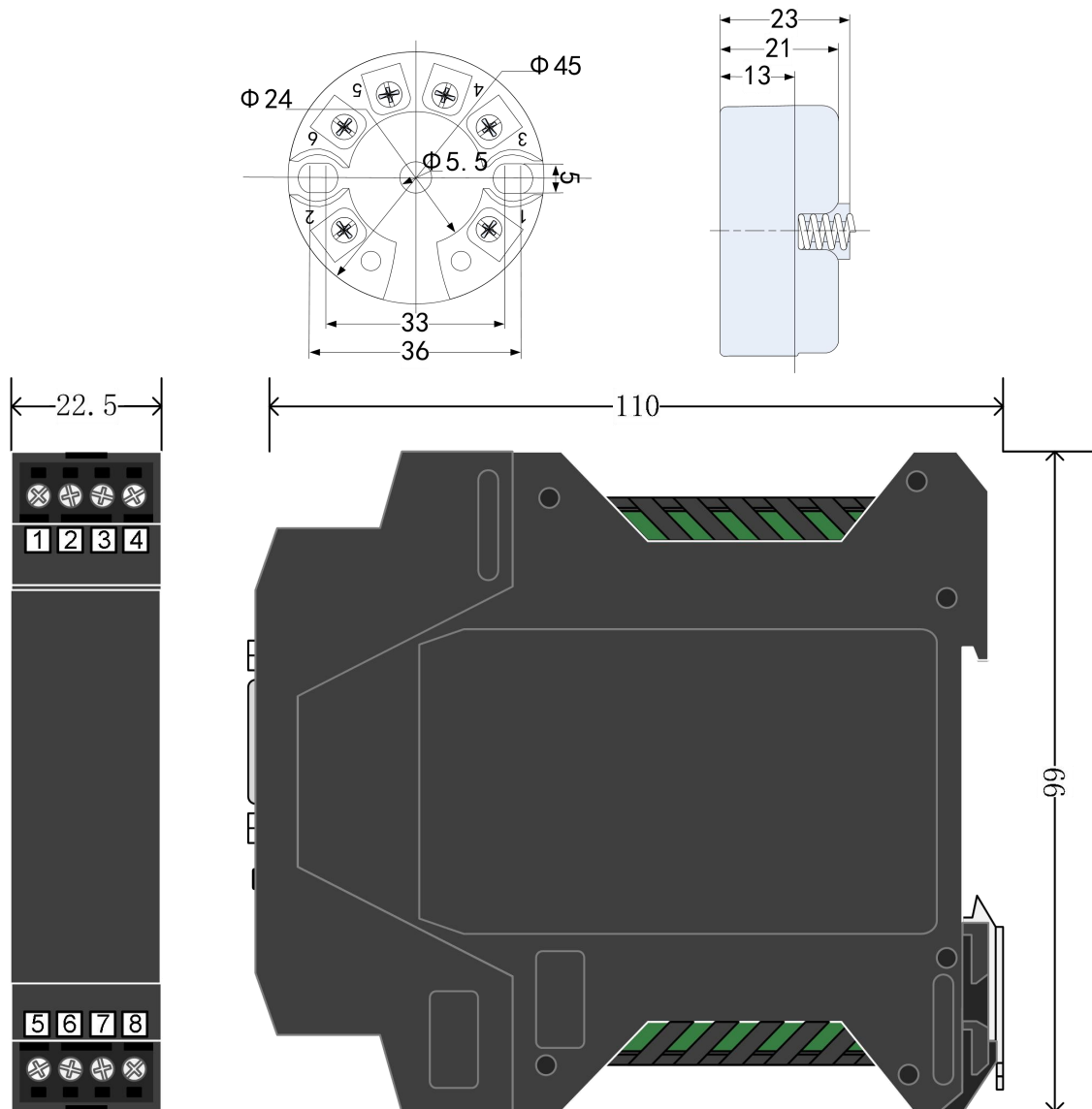

NCS-TT106F-R1

Figure 2.1 Dimension of Temperature Transmitter (Unit: mm)

### 2.2 Installation

Fix the temperature transmitter into the temperature housing or din rail by positioning the two screws through the positioning hole.

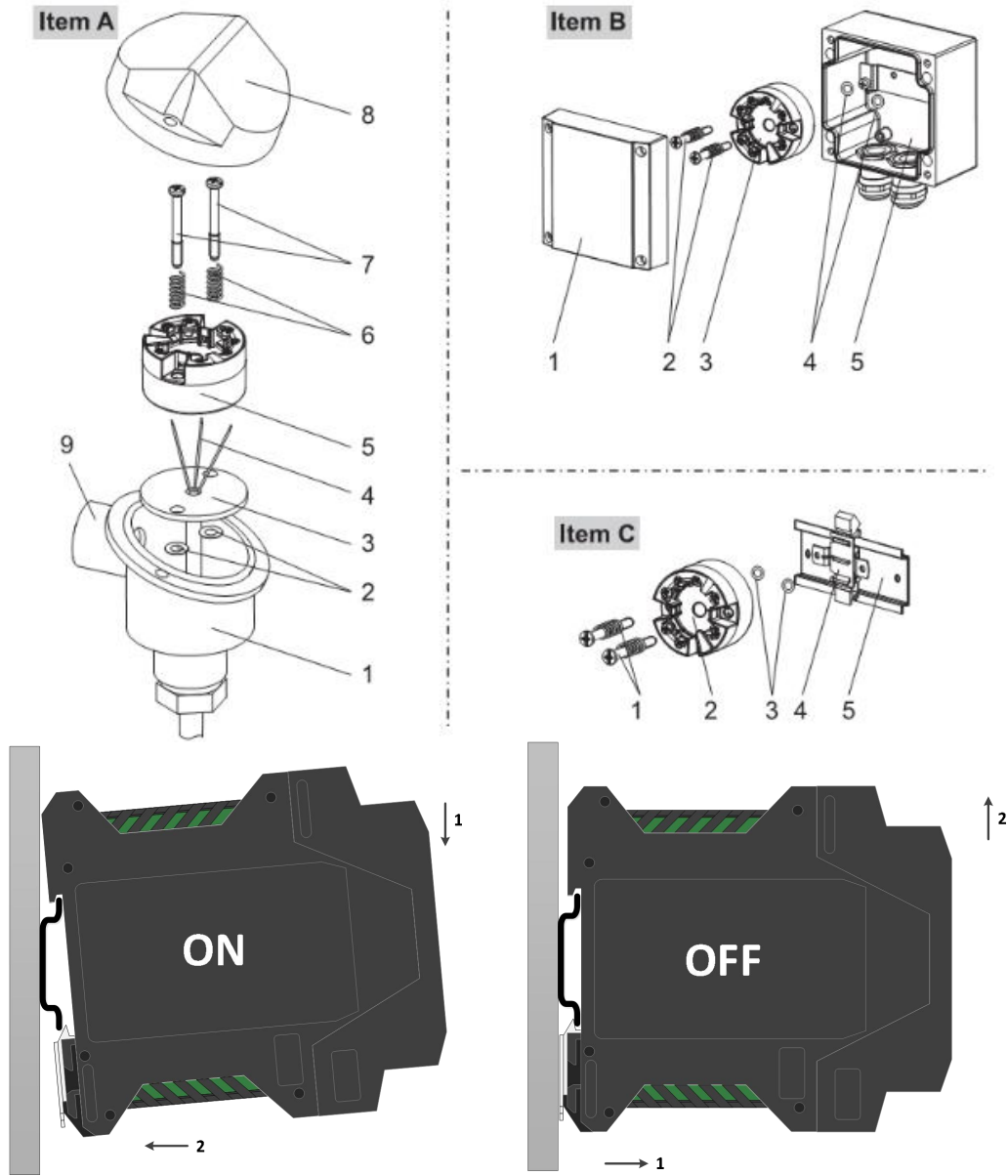

Figure 2.2 Installation

2.3 Wiring

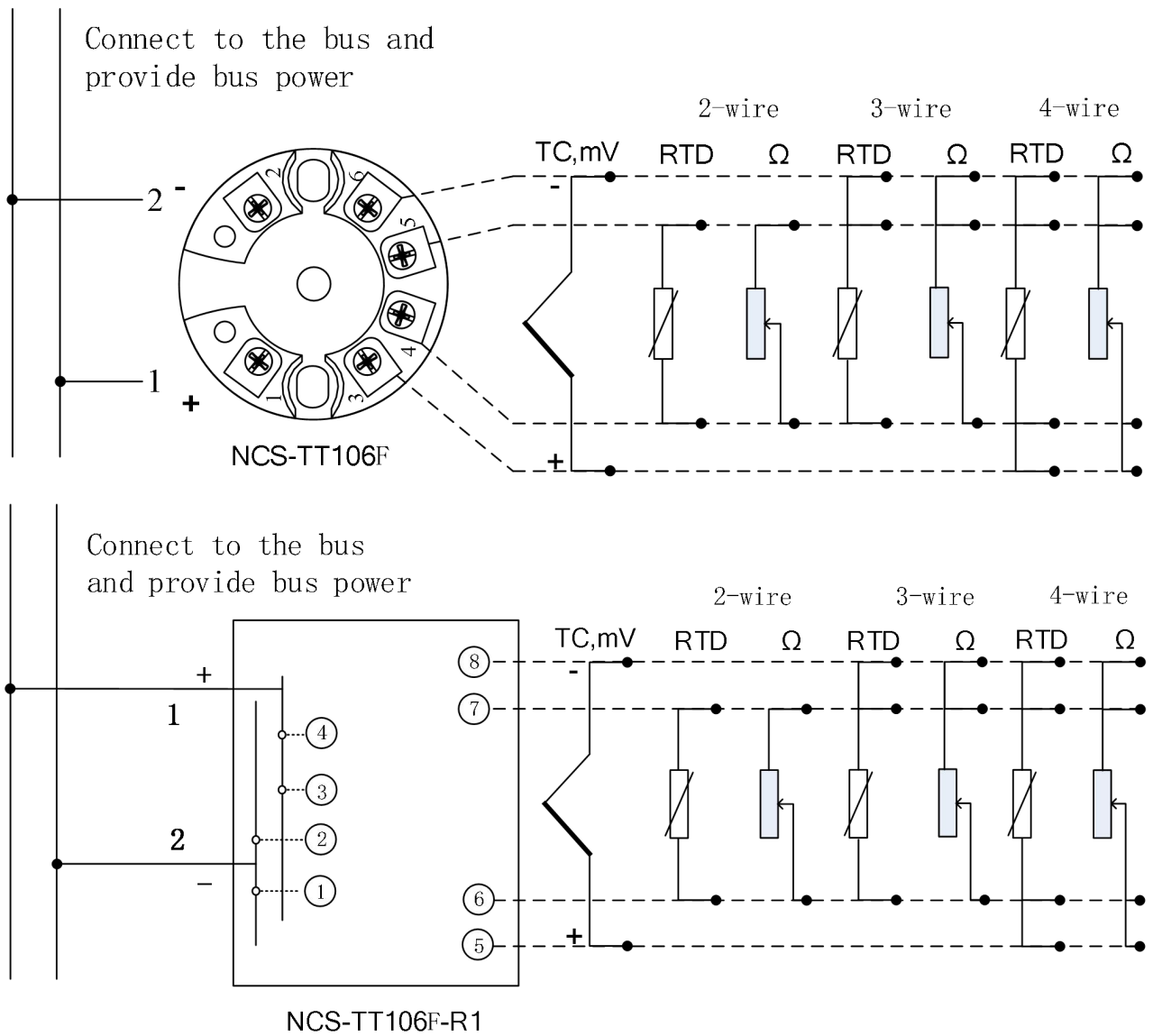

Figure 2.3 Wiring

The power supply of NCS-TT106F temperature transmitter and bus signal share a pair of cables, called bus cable. It is recommended to use the fieldbus dedicated cable recommended by IEC61158-2. The signal cable and bus cable should not share the conduit or open channel with the power cables of other equipment, and should be far away from high-power equipment. The shielded wires at both ends of the bus are grounded by single-ended grounding.

### 3 Foundation Fieldbus Protocol Temperature Transmitter Configuration

#### 3.1 Topology Connection

Foundation Fieldbus transmitter supports multiple network topology wiring methods, as shown in Figure 3.1 Figure 3.2 shows the bus connection of the FOUNDATION FIELDBUS transmitter. Both ends of the bus need to be connected with terminal matching resistors to ensure signal quality. The maximum length of the bus is 1900 meters, and it can be extended to 10 kilometers by using repeaters.

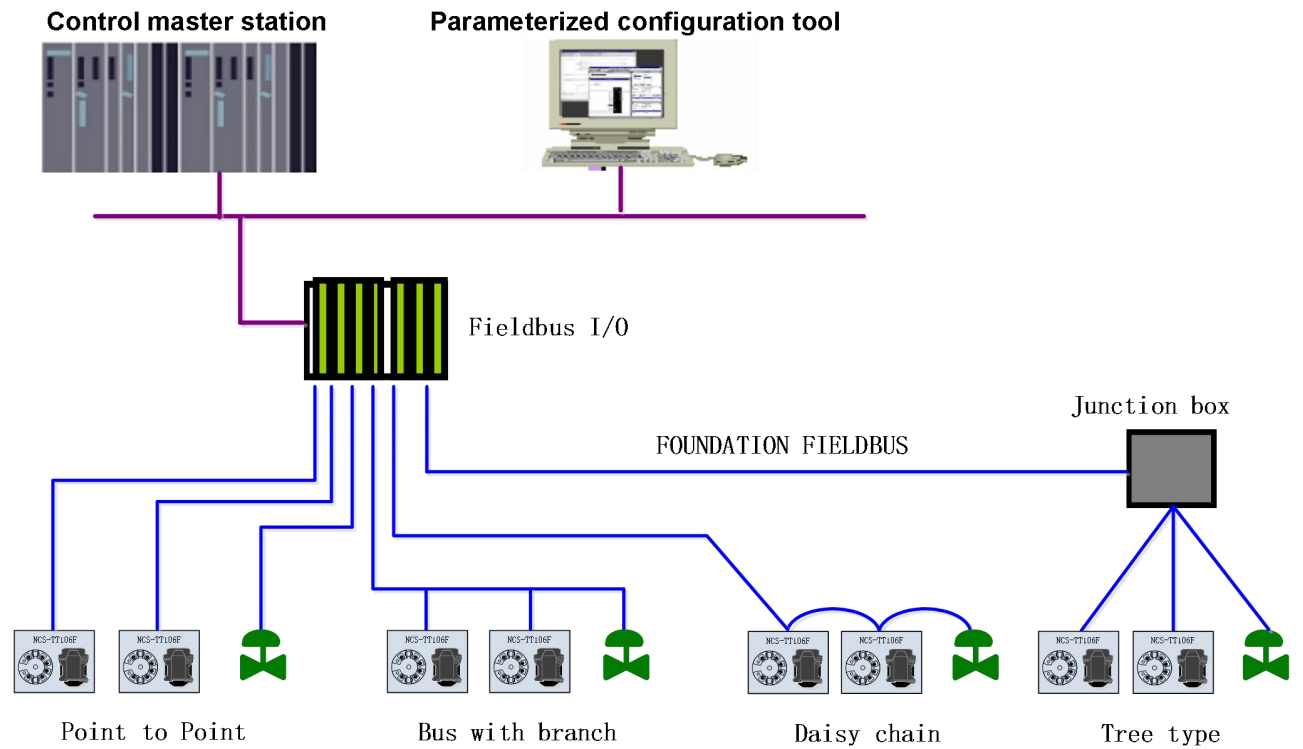

Figure 3.1 Foundation Fieldbus network topology

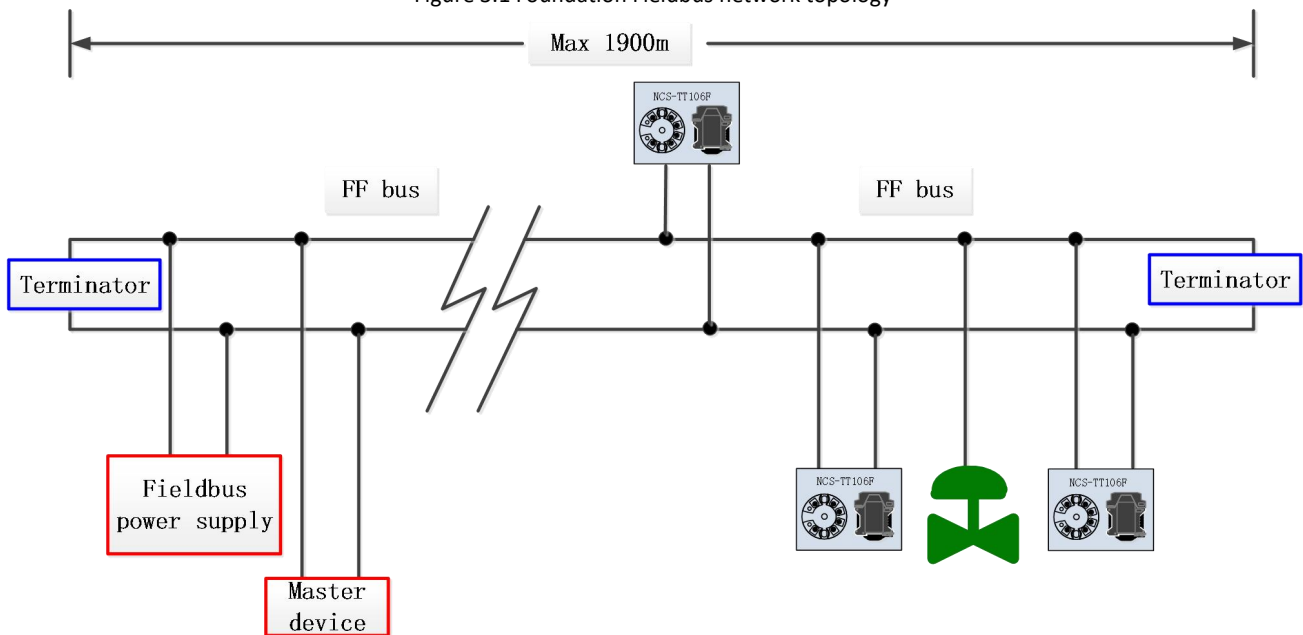

Figure 3.2 Foundation Fieldbus bus connection

### 3.2 Function block

The FOUNDATION FIELDBUS type NCS-TT106F temperature transmitter implements the FOUNDATION FIELDBUS standard function block, see the table below. For the configuration method of the function block, please refer to the FOUNDATION FIELDBUS protocol related documents.

Name	Description
Resource Block	Resource block, used to describe the characteristics of field devices, such as device name, manufacturer, and serial number. The resource block has no input or output parameters. A device usually has only one resource block
TEMP_SENSOR 1(TTB)	Transducer block, read the sensor hardware data, or write the field data to the corresponding hardware. Transducer block contains information such as range, sensor type, linearization, I / O data, etc.
CUSTOM_BLOCK1(CTB)	Transducer block, expand the function of transducer block 1, mainly to complete the user's secondary calibration and user-defined sensor type function
AI 1(AI)	Analog Input function block 1 (AI 1). Obtain the analog process value from the transducer block through the internal channel, process it, and provide the appropriate measured value to the master device through bus communication
AI 2(AI)	Analog Input function block 2 (AI 2). Obtain the ambient temperature value from the transducer block through the internal channel and process it, and provide the appropriate measured value to the master device through bus communication
PID1(PID)	Proportional-Integral-Derivative function block (PID). Use this function block to realize the split-range control process

### 3.3 Transducer block configuration example

NCS-TT106F temperature transmitter can connect various types of sensors, such as resistance sensor, RTD thermal resistance sensor, TC thermocouple sensor, -/ + 100mV signal, custom RTD thermal resistance sensor and custom TC thermocouple sensor. The following describes the connection and configuration of each type of sensor.

#### 3.3.1 Connecting a resistance sensor

NCS-TT106F temperature transmitter can measure 0-500Ω and 0-4000Ω resistance signals. When the resistance signal sensor is connected, the parameters in the transducer block are configured as follows:

SENSOR\_TYPE = 0-500Ω or 0-4000Ω  
 SENSOR\_CONNECTION = Two Wires or Three Wires or Four Wires  
 PRIMARY\_VALUE\_UNITS\_INDEX = Ohm or kOhm  
 RJ\_TYPE = N/A(ignore)

### 3.3.2 Connect RTD thermal resistance sensor

SENSOR_TYPE	=	CU50 or CU100 or PT100 or PT1000
SENSOR_CONNECTION	=	Two Wires or Three Wires or Four Wires
PRIMARY_VALUE_UNITS_INDEX	=	K or °C or °F or °R
RJ_TYPE	=	N/A(ignore)

### 3.3.3 Connect-/+ 100mV signal sensor

SENSOR_TYPE	=	-/+100mV
SENSOR_CONNECTION	=	Two Wires
PRIMARY_VALUE_UNITS_INDEX	=	mV
RJ_TYPE	=	N/A(ignore)

### 3.3.4 Connect TC Thermocouple Sensor

SENSOR_TYPE	=	T/CType B or T/CType E or T/CType J or T/CType K T/CType N or T/CType R or T/CType S or T/CType T
SENSOR_CONNECTION	=	Two Wires
PRIMARY_VALUE_UNITS_INDEX	=	K or °C or °F or °R
RJ_TYPE	=	No reference or Internal or External or External PT100

### 3.3.5 Custom TC thermocouple sensor

SENSOR_TYPE	=	Custom defined TC
SENSOR_CONNECTION	=	Two Wires
PRIMARY_VALUE_UNITS_INDEX	=	K or °C or °F or °R
RJ_TYPE	=	No reference

For custom TC thermocouple sensor measurement, you need to enter the polynomial value in the custom TC parameter in the transducer block CUSTOM\_BLOCK1 and the temperature value measured by the calculation formula. The following is an example of measuring a custom TC thermocouple sensor.

```
CUSTOM_TC_NAME = Custom TC Example
CUSTOM_TC_POLY_COUNT = 5
CUSTOM_TC_MIN_IN = -6500.0
CUSTOM_TC_MIN_OUT = -100.0
CUSTOM_TC_MAX_OUT = 1200.0
```

Example of custom TC thermocouple sensor polynomial coefficients

CUSTOOM_TC_POLY_X	max.input limit in $\mu\text{V}$ for POLY_X	4th degree coefficient for POLY_X	3th degree coefficient for POLY_X	2th degree coefficient for POLY_X	1st degree coefficient for POLY_X	0degree coefficient for POLY_X
CUSTOM_TC_POLY_1	-3200.0	-3.84E-13	-5.65E-9	-3.36E-5	-6.10E-2	-8.44E1
CUSTOM_TC_POLY_2	3500.0	-8.13E-15	7.29E-11	-4.18E-7	2.53E-2	-1.08E-2
CUSTOM_TC_POLY_3	10000.0	-1.35E-15	1.50E-11	1.41E-7	2.26E-2	4.18
CUSTOM_TC_POLY_4	30000.0	3.49E-18	2.19E-12	-1.53E-7	2.68E-2	-9.26
CUSTOM_TC_POLY_5	70000.0	6.27E-17	-8.76E-12	5.34E-7	8.69E-3	1.65E2

	3th degree coefficient	2th degree coefficient	1st degree coefficient	0 degree coefficient
CUSTOM_TC_RJ_POLY	-1.11E-4	2.65E-2	3.94E1	3.94E-1

For example, the input voltage of the TC terminal of the temperature transmitter is 5000  $\mu\text{V}$  and the temperature of the cold terminal is 25 ° C. According to the formula, the voltage value corresponding to the temperature of the cold terminal can be calculated:

$$\text{URJ} = 3.94 * 10^{-1} + 3.94 * 10^1 * 25 + 2.65 * 10^{-2} * 25^2 - 1.11 * 10^{-4} * 25^3 = 1000 \mu\text{V}$$

Add this voltage to the input terminal of TC (5000 + 1000) and then calculate the corresponding temperature value according to the calculation formula:

$$4.18 + 2.26 * 10^{-2} * 6000 + 1.41 * 10^{-7} * 6000^2 + 1.50 * 10^{-11} * 6000^3 - 1.35 * 10^{-15} * 6000^4 = 146.3 \text{ }^\circ\text{C}$$

### 3.3.6 Custom RTD thermal resistance sensor

SENSOR_TYPE	= Custom defined RTD
SENSOR_CONNECTION	= Two Wires or Three Wires or Four Wires
PRIMARY_VALUE_UNITS_INDEX	= K or °C or °F or °R
RJ_TYPE	= No reference

Custom RTD thermal resistance sensor measurement, you need to enter the value of the polynomial in the custom RTD parameter in the transducer block CUSTOM\_BLOCK1, and the temperature value measured by the calculation formula. You can refer to the way of custom TC to set.

## 3.4 Function configuration

NCS-TT106F intelligent temperature transmitter supports all mainstream FOUNDATION FIELDBUS master system (NI-FBUS Configurator of NI company, DeltaV of EMERSON, EN2FFR-1788 of Rockwell and other general FOUNDATION FIELDBUS configuration software) on the market for configuration . The following mainly uses NI company's NI-FBUS Configurator configuration software as an example to introduce the configuration and use method of NCS-TT106F temperature transmitter.

### 3.4.1 Setting up the configuration environment

- 1) PC, the operating system is Windows XP, Windows7 or Windows10;
- 2) NI USB-8486, H1 bus power supply, H1 terminator;
- 3) NI-FBUS Configurator;

As shown in Figure 3.3 below is a demonstration environment built using NI's BUS-8486 as an example.

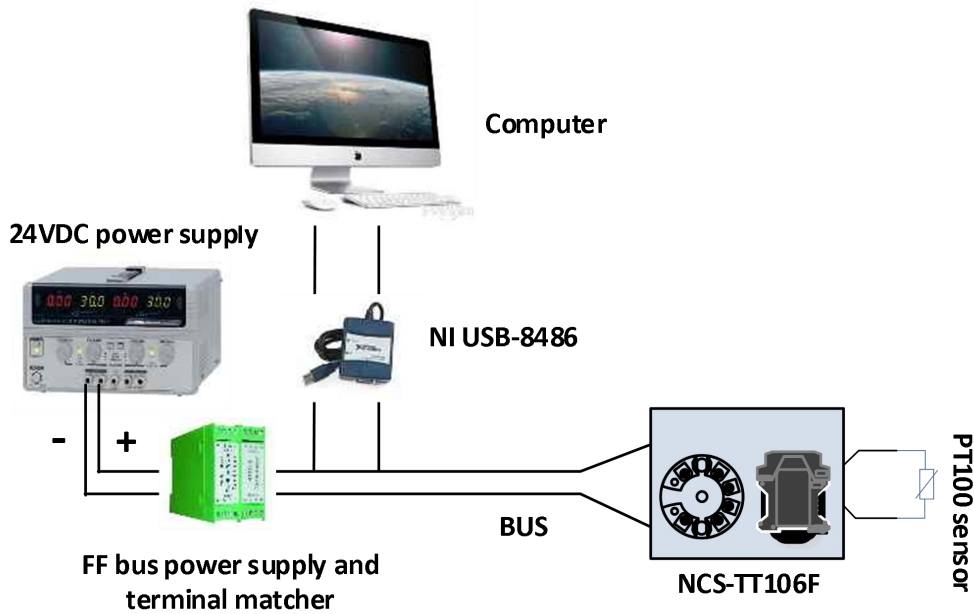

Figure 3.3 NCS-TT106F hardware test environment

### 3.4.2 Import DD file

Open the Interface Configuration Utility software in the NI software and import it according to the steps shown in Figure 3.4 below. After successful DD import, there will be a successful prompt.

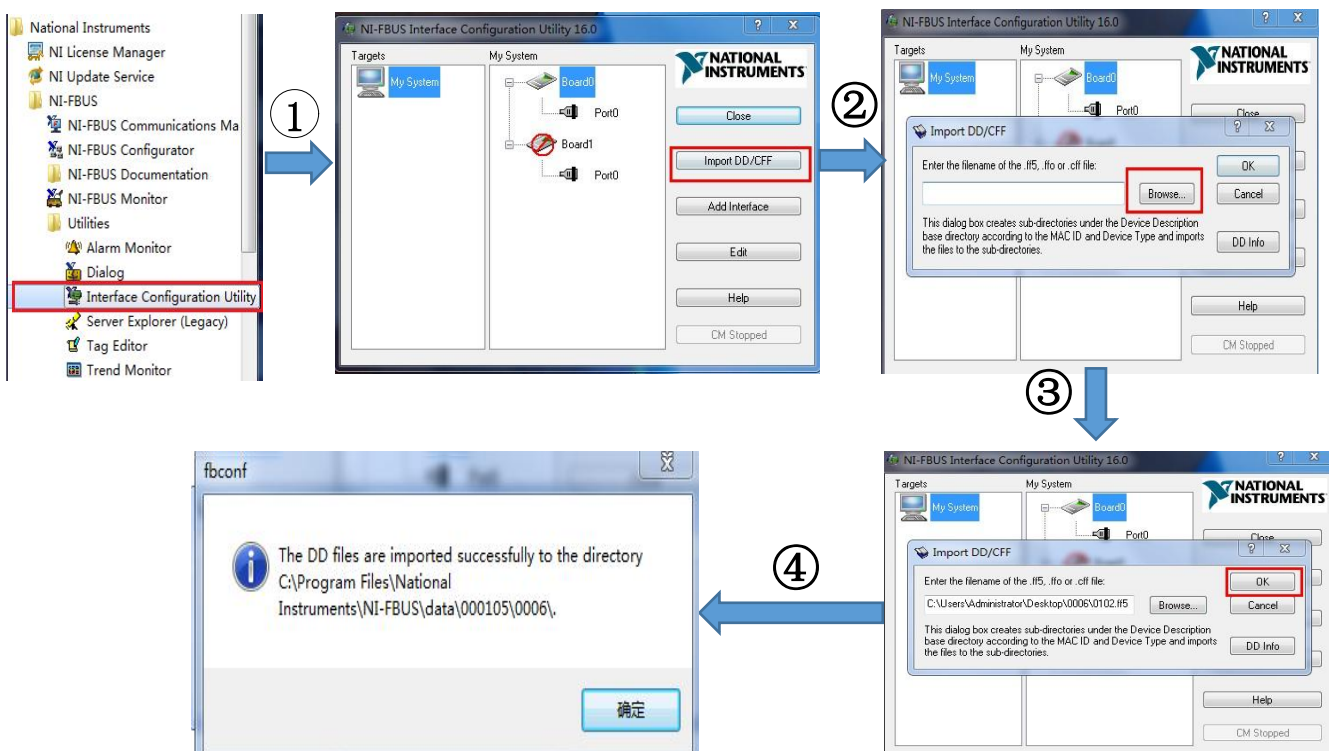

Figure 3.4 DD import interface

### 3.4.3 Device online detection

According to the wiring diagram of NCS-TT106F, connect the two lines FF + and FF- to the FOUNDATION FIELDBUS bus. Open the NI-FBUS Configurator software, and the NCS-TT106F device will be detected on the interface. As shown in Figure 3.5 below. In the figure, NCS-TT106F has one resource block, 2 transducer blocks, 2 AI function blocks and 1 PID function block.

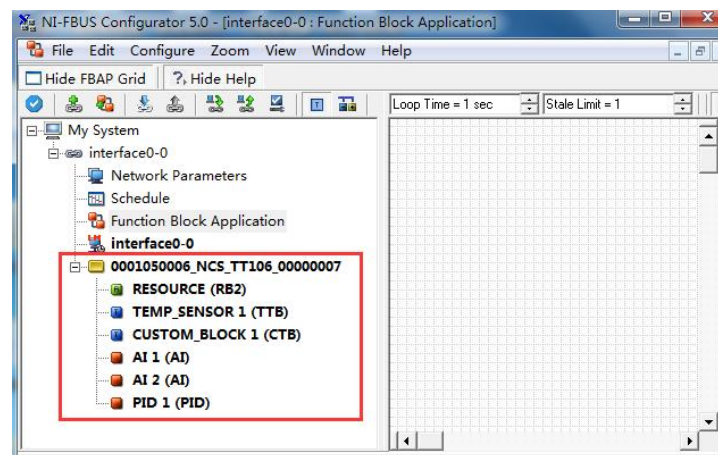

Figure 3.5 The device goes online normally

### 3.4.4 Sensor configuration

When using the NCS-TT106F temperature transmitter, the related parameters should be configured in the transducer block according to the connected sensor model. Open the transducer block TEMP\_SENSOR1, change the TARGET in the MODE\_BLK parameter of the transducer block to OOS, and configure the sensor type and connection cable system under the SENSOR\_TYPE and SENSOR\_CONNECTION lists. Take the PT100 three-wire system as an example in Figure 3.6 below.

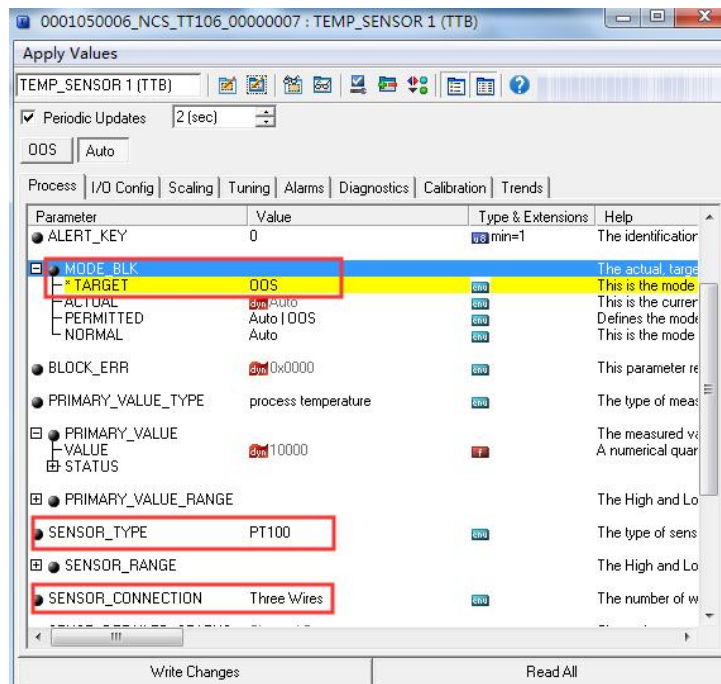

Figure 3.6 Sensor configuration

After the configuration is completed, modify the TARGET in the MODE\_BLK parameter of the transducer block to Auto, and the ACTUAL parameter in the MODE\_BLK parameter should be Auto, otherwise modify the configuration according to the prompt of the BLOCK parameter. You can see the current temperature value and status collected by the PT100 sensor in the PRIMARY\_VALUE parameter. As shown in Figure 3.7 below.

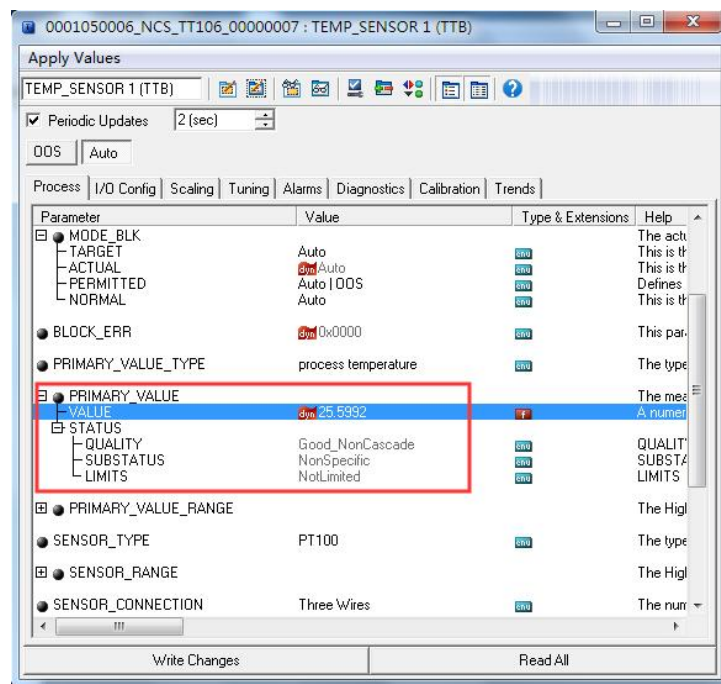

Figure 3.7 Temperature measurement value display interface

### 3.4.5 Two-wire zero calibration configuration

In the two-wire measurement, the two-wire zero calibration can be performed by the TWO\_WIRES\_COMPENSATION parameter of the transducer block. The specific method is as follows:

First, give the channel zero value, that is, short the two ends of the channel.

Secondly, set the parameter TWO\_WIRES\_COMPENSATION to Start, click the "Write Changes" button.

Finally, after successful writing, read the TWO\_WIRES\_COMPENSATION parameter and click the "Read All" button until the two-wire zero calibration is successful when the value of this parameter is Finish.

### 3.4.6 Two-point linearization calibration

NCS-TT106F temperature transmitter has undergone rigorous calibration work before leaving the factory, in general, no user calibration is required. Users can use parameters CAL\_POINT\_HI, CAL\_POINT\_LO, and CAL\_UNIT to achieve two-point linearization calibration. The following uses mV signal two-point linearization calibration as an example. The operation steps are as follows:

(1) Set the TEMP\_SENSOR1 MODE parameter of the transducer block to OOS, and set the SENSOR\_TYPE parameter to  $\pm 100\text{mV}$ . Set the calibration unit parameter CAL\_UNIT to mV according to the sensor type, and set the parameter SENSOR\_CAL\_METHOD to "User Trim Standard Calibration". The setting diagram is shown in Figure 3.8 below.

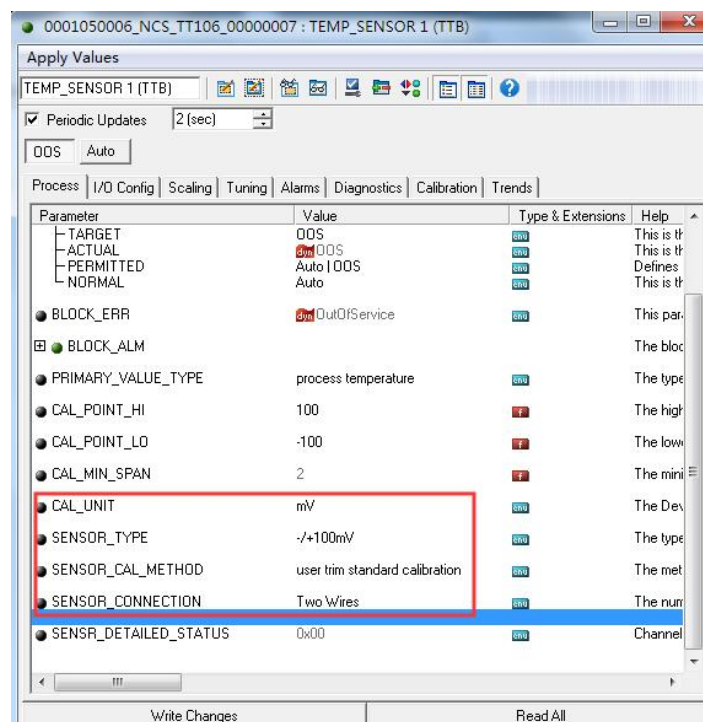

Figure 3.8 Two-point linearization calibration configuration diagram

(2) Calibrate the lower limit mV signal to the acquisition channel through the standard mV signal source. After stabilization, write the output value of the standard mV signal source to the CAL\_POINT\_LO parameter and click the "Write Changes" button. Similarly, the standard mV signal source is used to output the upper calibration mV

signal to the acquisition channel. After stabilization, write the output value of the standard mV signal source to the CAL\_POINT\_HI parameter and click the "Write Changes" button. No prompt for writing errors indicates that the calibration was successful. As shown in Figure 3.9 below, the lower limit of the calibration mV signal is -80mV, and the upper limit of the calibration mV signal is 80mV. **Note that the written calibration data and the actual input channel data must not have a large deviation, otherwise the calibration will fail.**

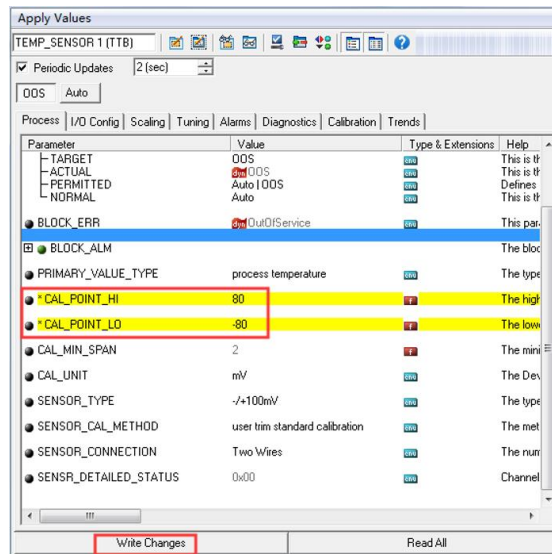

Figure 3.9 Two-point linearization calibration configuration diagram

After completing the above steps, set the TEMP\_SENSOR1 MODE parameter of the transducer block to Auto, and mV signal acquisition can be performed normally. BIAS is the offset parameter, and the offset function is valid in this mode. In Celsius, the two-point linearization calibration principle of the ohmic signal is the same as the calibration principle of the mV signal.

### 3.4.7 Multipoint linearization calibration

NCS-TT106F temperature transmitter has the function of multi-point linearization calibration. It can support up to 16 calibration points. The user can choose whether to enable it according to his needs. Through the calibration parameters TAB\_X\_Y\_VALUE1-TAB\_X\_Y\_VALUE16 of the CUSTOM\_BLOCK1 transducer block, the user can complete the multi-point linear calibration of the instrument by himself. The calibration procedure is as follows:

( 1 ) The NCS-TT106F temperature transmitter provides 16 calibration point inputs, namely the TAB\_X\_Y\_VALUE1-TAB\_X\_Y\_VALUE16 array of parameters of the transducer block. The user can write the output values to be calibrated into the array in turn and select a good unit. For example, when performing three-point interpolation calibration, the user can select 10, 20, and 30 as calibration points, and write the three values in the second place in the TAB\_X\_Y\_VALUE1, TAB\_X\_Y\_VALUE2, and TAB\_X\_Y\_VALUE3 arrays, as shown in Figure 3.10.

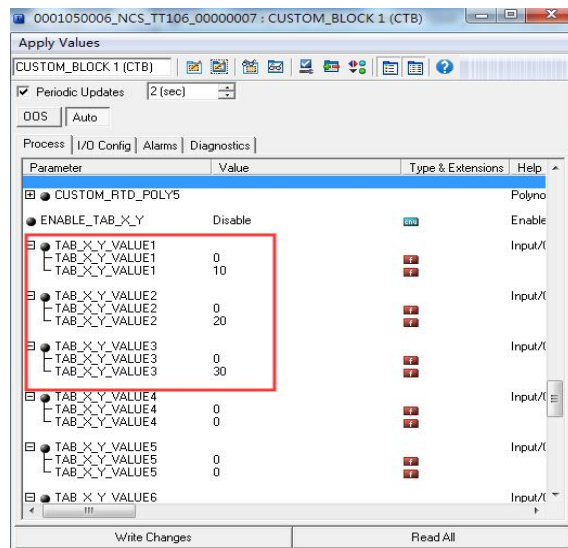

Figure 3.10 Calibration point configuration

(2) Input the standard signal through the standard source, and open the transducer block TEMP\_SENSOR1 in the configuration software, read the value of the parameter PRIMARY\_VALUE, and write the value to the first place in the TAB\_X\_Y\_VALUE1, TAB\_X\_Y\_VALUE2, and TAB\_X\_Y\_VALUE3 arrays. For example, write the read 10.2, 20.5, 30.4 in the array, and set the parameter ENABLE\_TAB\_X\_Y to "Enable" as shown in Figure 3.11. This is the end of calibration work.

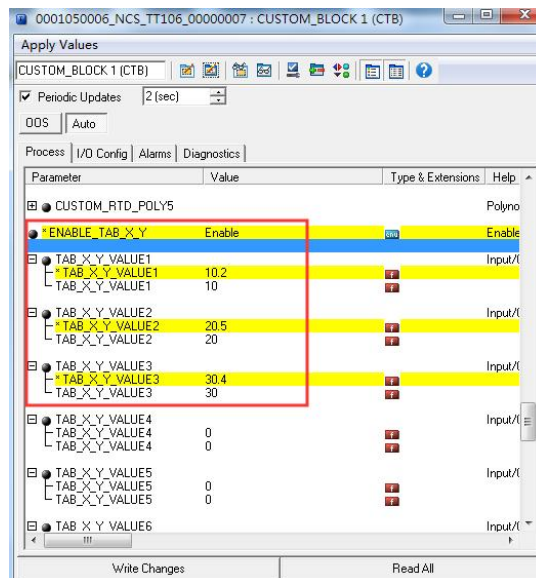

Figure 3.11 Acquisition parameter configuration

(3) Open the transducer block TEMP\_SENSOR1, set the MODE parameter to OOS, and set the parameter SENSOR\_CAL\_METHOD to "User Trim special Calibration". After successful setting, set the MODE parameter to Auto, and the temperature transmitter will work according to the calibrated characteristic curve.

### 3.4.8 Enabling cold junction temperature compensation

When using the thermocouple as the sensor, the user can set the cold junction compensation through the

parameter RJ\_TYPE, and set it to Internal to enable the internal cold junction compensation. At this time, the value of RJ\_TEMP is the temperature value measured internally, that is, the value of the parameter SENCANDARY\_VALUE; External can configure a fixed cold junction compensation value by setting the value of EXTERNAL\_RJ\_VALUE. At this time, the value of RJ\_TEMP is the value of EXTERNAL\_RJ\_VALUE; when it is set to External PT100, the temperature can be measured by an external two-wire PT100 sensor as the cold junction compensation value; setting No reference can disable cold junction compensation, as shown in Figure 3.12.

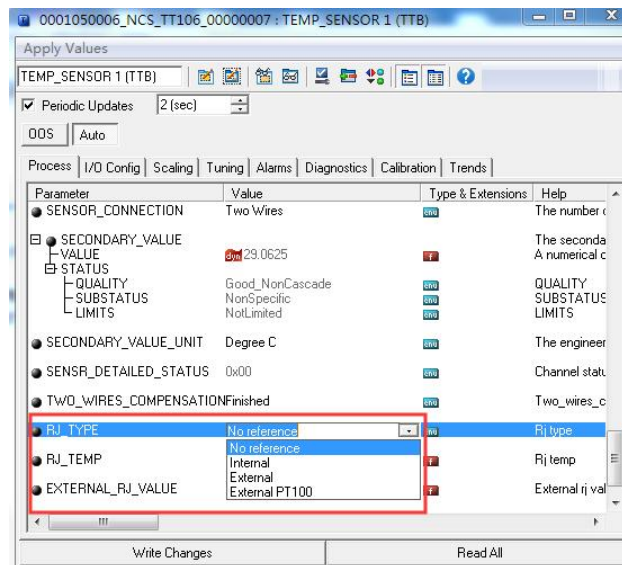

Figure 3.12 RJ\_TYPE configuration

### 3.5 Function block configuration

NCS-TT106F temperature transmitter has 2 AI function blocks and a PID function block, each function block conforms to the FOUNDATION fieldbus standard. When NCS-TT106F temperature transmitter is applied in engineering, it needs to be configured and configured And download function blocks to complete temperature collection and logic control. The following takes the configuration of the AI function block as an example for detailed description. The specific configuration steps are as follows:

(1) After ensuring that the NCS-TT106F transducer block is configured correctly and are in Auto mode, open the "Function Block Application" configuration interface in the NI software, drag the AI1, AI2, and PID function blocks into the configuration interface to connect AI1 and AI2 OUT to PID IN and CAS\_IN respectively. As shown in Figure 3.13 below.

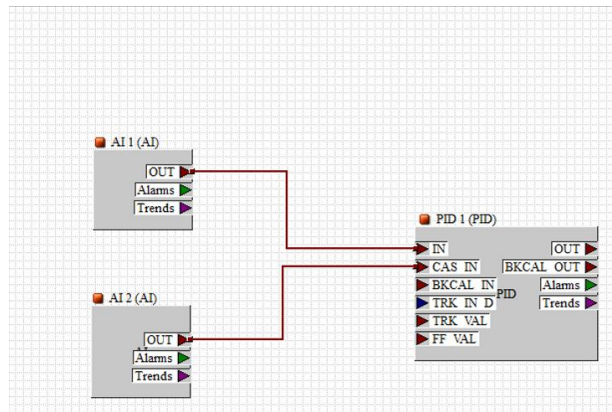

Figure 3.13 Function block configuration diagram

(2) To download the configuration information, click the "Download Project" button on the NI software to download the configuration project. The download interface is shown in Figure 3.14 below.

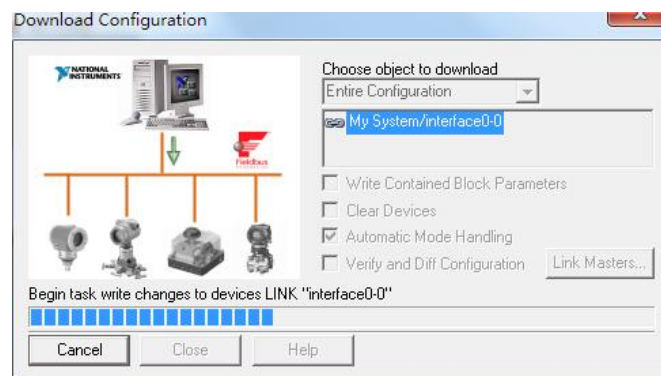

Figure 3.14 Configuration engineering download interface

(3) After the configuration information is downloaded successfully, you need to configure the parameters in the AI function block. Common configuration parameters are CHANNEL, XD\_SCALE, OUT\_SCALE, and L\_TYPE. Let's take the AI1 function block as an example for configuration, open the AI1 function block, modify the TARGET in the MODE\_BLK parameter to OOS, modify the upper and lower limits and unit parameters of XD\_SCALE, modify CHANNEL to Primary Value, modify L\_TYPE to Direct, and click "Write Changes" The button finishes writing the modified parameters. As shown in Figure 3.15.

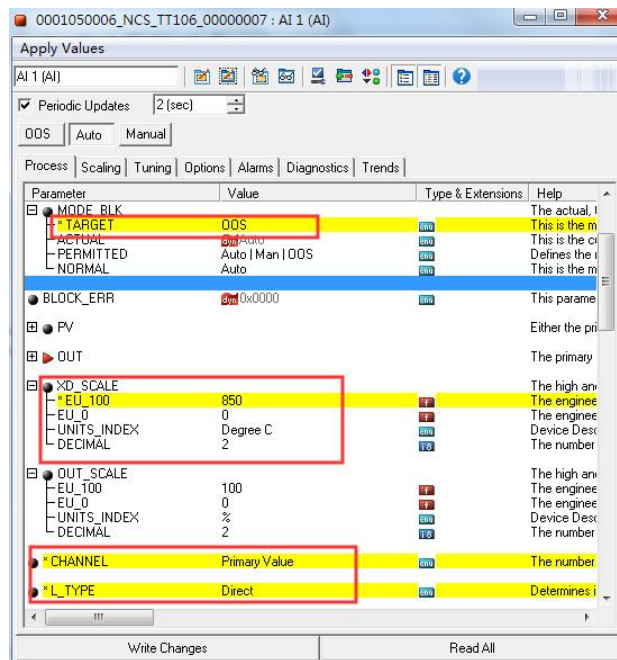

Figure 3.15 AI1 function block configuration interface

(4) After completing the configuration of the AI function block, modify the TARGET in the MODE\_BLK parameter of the AI1 function block to Auto, and the ACTUAL parameter in the MODE\_BLK parameter should be Auto, otherwise modify the configuration according to the prompt of the BLOCK parameter. In the PV and OUT parameters, you can see that the temperature value of the AI1 function block is 25.6778 and the status is Good\_NonCascade. At this time, the AI1 function block is normal, as shown in Figure 3.16 below.

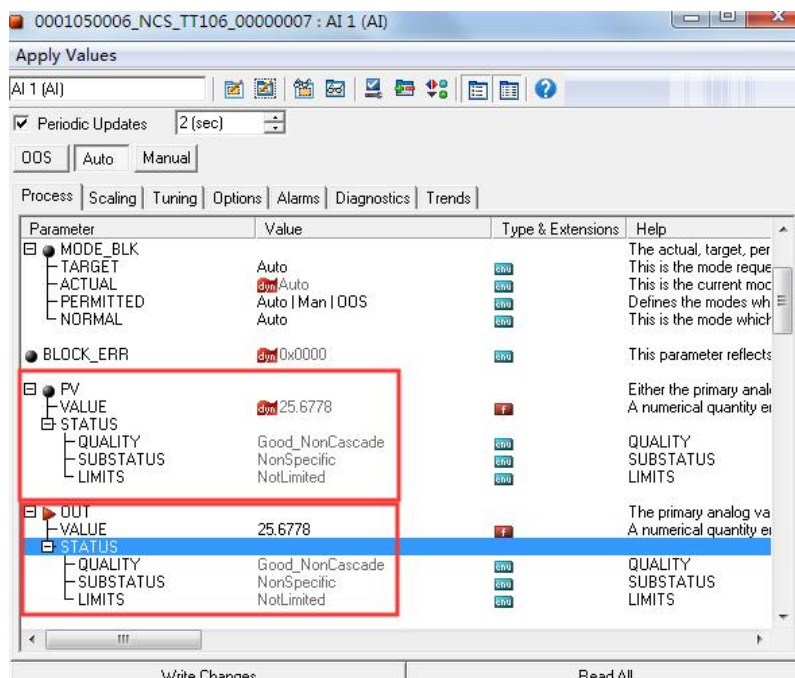

Figure 3.16 AI1 function block acquisition value and status

The configuration of the AI2 function block is the same as that of the AI1 function block, which is not described here. The user can configure the AI1 function block according to the requirements.

What needs to be emphasized here is: different algorithms of AI function blocks in different actual modes:

- ① When the actual working mode is O / S, the output parameter OUT status value is Status = Bad; Sub\_status = Out of Service. The parameter value is the value of the parameter IN.
- ② When the actual working mode is MAN, if the Uncertain if Man mode option in the STATUS\_OPTS parameter is set, the output parameter OUT status value is Quality = Uncertain; Sub\_status = Non-specific. In contrast, the output parameter OUT status value is Quality = Good (NC); Sub\_status = Non-specific, the value is the last output parameter OUT value or a value written by the interface device.
- ③ When the actual working mode is AUTO, the value of the output parameter OUT is obtained according to the basic algorithm of the AI block. The state value of the output parameter OUT is determined according to the state value of the parameter IN and related options in the parameter STATUS\_OPTS. The basic algorithm of AI when the actual working mode is AUTO:

First, the channel value (Channel\_Val) is obtained from the input transducer block through the channel parameter (CHANNEL) and sent to the transducer block variable of the simulation parameter (SIMULATE). When the simulation is enabled (Enable / Disable = Enable), the simulation value in the simulation variable is the input value; otherwise, the input value is the channel value from the transmission block.

Secondly, after determining the input value, perform range conversion, linearization, small signal removal and filtering, etc., and finally get the output value (including the value and status).

Finally, the formula for calculating the field value is as follows:

$$\text{FIELD\_VAL} = 100 * (\text{Channel\_val} - \text{EU@0\%}) / (\text{EU@100\%} - \text{EU@0\%}) * [\text{XD\_SCALE}]$$

The calculation method of OUT output value depends on the linearization type. There are three types of linearization type L\_TYPE: Direct, Indirect, and Indirect Square Root. The calculation formula is as follows. Among them, the two parameters XD\_SCALE and OUT\_SCALE record the input adjustment block and output value range. And unit, EU @ 100% and EU @ 0% are the measured value at full scale and zero point respectively.

Direct: PV = channel value

Indirect: PV = (FIELD\_VAL/100) \* (EU@100% - EU@0%) + EU@0% [OUT\_SCALE]

Ind Sqr Root: PV = sqrt(FIELD\_VAL/100) \* (EU@100% - EU@0%) + EU@0% [OUT\_SCALE]

(4) Monitor the output value and status of the function block through the configuration interface, click the "Monitoring Mode" button on the NI configuration interface, select the input and output parameters to be monitored according to the prompt interface, and click the "Start Monitoring" button to start monitoring. See Figure 3.17 below It is the configuration monitoring interface.

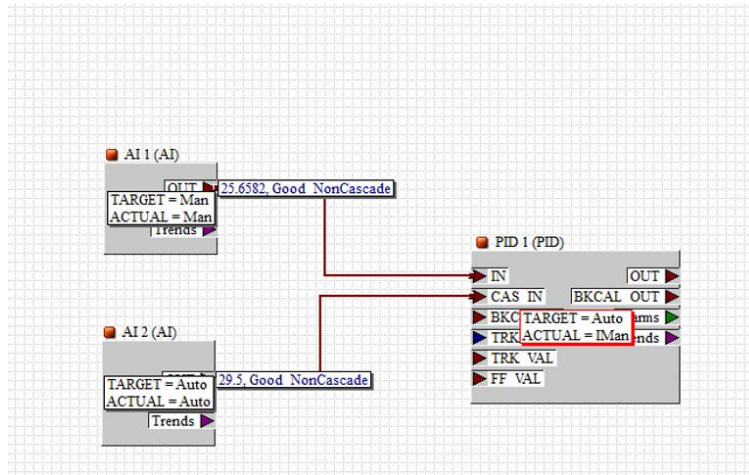

Figure 3.17 Function block configuration monitoring interface

## 4 Maintenance

Phenomenon	Solution
No communication	<p><b>Temperature Transmitter Connection</b>                      Check the bus cable connection                      Check bus power polarity                      Check bus cable shield, whether it is single point earthing or not</p>
	<p><b>Bus power</b>                      At the temperature transmitter end, the output voltage of the bus power supply should be between 9 and 32V.                      In addition, bus noise and ripple should meet the following requirements:                      1) Peak-to-peak noise 16mV, 7 ~ 39kHz;                      2) Peak-to-peak noise 2V, 47 ~ 63Hz, non-intrinsically safe environment;                      3) Peak-to-peak noise 0.2V, 47 ~ 63Hz, intrinsically safe environment;                      4) Peak-to-peak noise of 1.6V, 3.9M ~ 125MHz.</p>
	<p><b>Network Connection</b>                      Check network topology structure                      Check terminal matcher and wiring                      Check the length of main trunk and branch</p>
	<p><b>Address Conflict</b>                      The factory default address of the temperature transmitter is 247, try to avoid address conflicts. However, there may still be address conflicts on a network segment. When a conflict occurs, sometimes the conflicting device will go online with a temporary address. Sometimes it can't go online at all. You can power off the conflicting devices first, and then power on one by one until all go online.</p>
	<p><b>Temperature Transmitter Failure</b>                      Replace the temperature transmitter with others for testing.</p>
Reading Error	<p><b>Temperature Module Connection Failure</b>                      Check sensor short circuit, open circuit, and earthing.                      Check sensor</p>
	<p><b>Noise Disturb</b>                      Adjust damping                      Check the house earthing                      Check if the terminal is moist                      Check the cable is away from the strong electromagnetic interference</p>
	<p><b>Software Configuration</b>                      Check sensor type configuration                      Check function block parameter configuration</p>
	<p><b>Temperature Transmitter Failure</b>                      Replace the temperature module with others for testing.</p>

## 5 Technical specifications

### 5.1 Basic parameters

Bus interface	FOUNDATION FIELDBUS
Bus power	9~32VDC 9~17.5VDC (Intrinsically safe)
Input signal	Pt100、Pt1000、CU50、CU100、0~500Ω、0~4000Ω resistance; B E J K N R S T thermocouple、-100mV~100mV、Custom defined TC、Custom defined RTD
Number of channels	Single channel
RTD wiring	2-wire、3-wire、4-wire
Update time	0.5s
Operating temperature	-40~85°C
Storage temperature	-40~85°C
Humidity range	5~95%RH
Electrical isolation	1000VAC
Voltage effect	±0.005%/V
Protection level	Terminal IP00 ;Housing IP40
Explosion-proof	Ex ia IIC T4 Ga
EMC	GB/T 18268.1-2010 Immunity requirements for industrial sites in "Electromagnetic Compatibility Requirements for Electrical Equipment for Measurement, Control, and Laboratory Use Part 1: General Requirements" GB/T 18268.25-2010 "Electromagnetic compatibility requirements for electrical equipment for measurement, control and laboratory use-Part 25: Special requirements. Test configuration, working conditions and performance criteria for field devices whose interfaces conform to IEC 61784-1, CP 3/2"

### 5.2 Thermal resistance technical index

#### ● RTD Normal temperature accuracy index (25°C)

Signal type	Recommended range (°C)	Accuracy	Temperature drift (per °C)
Resistance signal	0~500Ω	±0.04Ω	±0.001Ω
	0~4000Ω	±0.35Ω	±0.015Ω
PT100	-200~850°C	±0.15°C	±0.003°C
PT1000	-200~850°C	±0.15°C	±0.005°C
CU50	-50~150°C	±0.15°C	±0.005°C
CU100	-50~150°C	±0.10°C	±0.003°C

#### ● RTD Other technical indicators

Wiring	2、3、4
Common mode rejection ratio	≥70dB (50Hz & 60HZ)
Differential mode rejection ratio	≥70dB (50Hz & 60HZ)

### 5.3 Thermocouple technical indicators

● Thermocouple room temperature accuracy index (25°C)

Signal type	Range	Recommended range	Accuracy	Temperature drift (per °C)
mV	-100mV~+100mV	-100mV~+100mV	±0.025mV	±0.001 mV
B	0°C~1820°C	500°C~1810°C	±0.77°C	±0.050°C
E	-270°C~1000°C	-200°C~1000°C	±0.20°C	±0.025°C
J	-210°C~1200°C	-190°C~1200°C	±0.35°C	±0.01°C
K	-270°C~1372°C	-200°C~1372°C	±0.40°C	±0.025°C
N	-270°C~1300°C	-190°C~1300°C	±0.50°C	±0.015°C
R	-50°C~1768°C	0°C~1768°C	±0.75°C	±0.023°C
S	-50°C~1768°C	0°C~1768°C	±0.70°C	±0.023°C
T	-270°C~400°C	-200°C~400°C	±0.35°C	±0.015°C

● Other technical indicators of thermocouple

Compensation accuracy	±0.5°C
Sensor type	B, E, J, N, K, R, S, T; -100mV~+100mV Voltage
Common mode rejection ratio	≥70dB (50Hz & 60HZ)
Differential mode rejection ratio	≥70dB (50Hz & 60HZ)

### 5.4 Physical characteristics

Size	NCS-TT106F: 45*23mm; NCS-TT106F-R1: 110*99*22.5mm
Housing material	Nylon



**Microcyber Corporation**

**Web:**<http://www.microcyber.cn/en>

**Add:** 17-8 Wensu Street, Hunnan New District,  
Shenyang, China 110179

**Tel:** 0086-24-31217278 / 31217280

**Fax:** 0086-24-31217293

**Email:** [sales@microcyber.cn](mailto:sales@microcyber.cn)